

Pre-H Service Data Sheet 1 of 5

WARNING

Turbochargers can be hazardous when not used as specified by the manufacturer. To prevent damage and personal injury:

- Always use the turbocharger part number specified by the engine manufacturer.
- Use only in applications approved by the engine manufacturer.
- Do not touch before checking surface temperatures.
- Do not work on a running turbocharger or engine.
- Do not modify the turbocharger in any way.
- Disassemble and re-assemble using the engine manufacturer's instructions.
- Use only approved spare parts.

For advice on the safe use of turbochargers contact www.holset.com

Locknut, Compressor Wheel (Item 61)

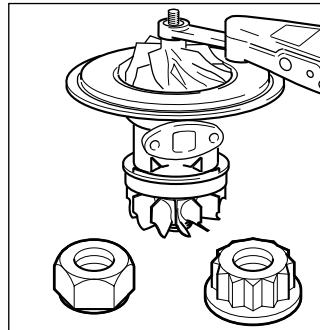

Bolt, Turbine Housing (Item 57)

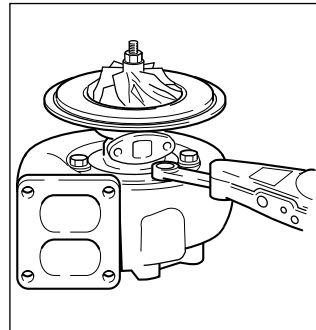

Bolt, Compressor Housing (Item 59)

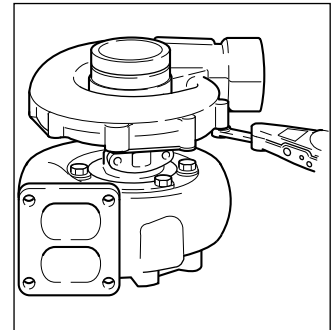
**Turbo Model****Nm (lb. in)****Nm (lb. in)****Nm (lb. in)**

Turbo Model	Nm (lb. in)		Nm (lb. in)	Nm (lb. in)
	6 pt. Hexagon	12 pt. Hexagon		
3 in/3A	20.3 (180)	N/A	16.3 (144)	10.9 (96)
3FD/3FE/3FJ/3LE	18.1 (160)	N/A	N/A	8.5 (75)
3LD	18.1 (160)	N/A	N/A	8.5 (75)
4 in/4B	40.7 (360)	N/A	16.3 (144)	10.9 (96)
4HD	40.7 (360)	N/A	16.3 (144)	8.5 (75)
4LE/4LF/4LG	40.7 (360)	N/A	N/A	8.5 (75)
4LEV/4LEK/4LFK	40.7 (360)	N/A	31.6 (280) - see note 6	8.5 (75)
4LGK	40.7 (360)	N/A	31.6 (280) - see note 6	8.5 (75)
4LGZ	40.7 (360)	N/A	N/A	8.5 (75)
4MD	40.7 (360)	N/A	N/A	8.5 (75)
4MF	50.8 (450)	N/A	16.3 (144)	8.5 (75)
6 in	61.0 (540)	N/A	16.3 (144)	10.9 (96)
6D/6LD	81.3 (720)	N/A	16.3 (144)	10.9 (96)

CAUTION

Always refer to *Service Notes* before using this service data.

Pre-H Service Data Sheet 2 of 5

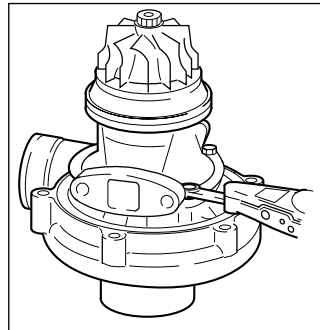
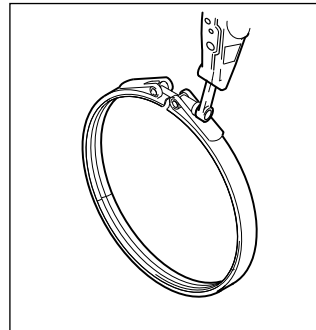
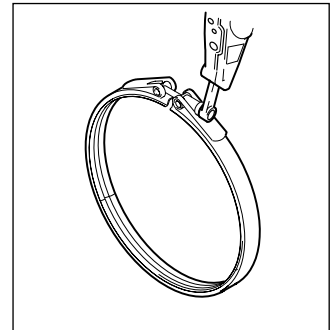
Screw, Bearing
Housing (Item 56)Locknut, V-Band
Turbine (Item 28)Locknut, V-Band
Compressor (Item 29)

Turbo Model

Nm (lb. in)

Nm (lb. in)

Nm (lb. in)

Turbo Model	Nm (lb. in)	Nm (lb. in)	Nm (lb. in)
3 in/3A	16.3 (144)	N/A	N/A
3FD/3FE/3FJ/3LE	N/A	8.5 (75)	N/A
3LD	N/A	8.5 (75)	N/A
4 in/4B	27 (240)	N/A	N/A
4HD	N/A	N/A	8.5 (75)
4LE/4LF/4LG	N/A	8.5 (75)	N/A
4LEV/4LEK/4LFK	N/A	8.5 (75)	N/A
4LGK	N/A	8.5 (75)	N/A
4LGZ	N/A	8.5 (75)	N/A
4MD	N/A	8.5 (75)	8.5 (75)
4MF	N/A	N/A	N/A
6 in	N/A	N/A	N/A
6D/6LD	27 (240)	N/A	N/A

CAUTION

Always refer to [Service Notes](#) before using this service data.

Pre-H Service Data Sheet 3 of 5

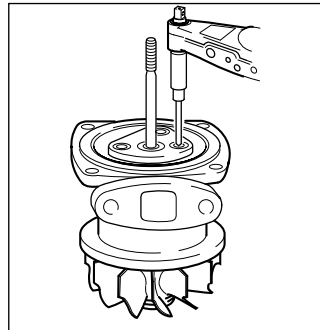
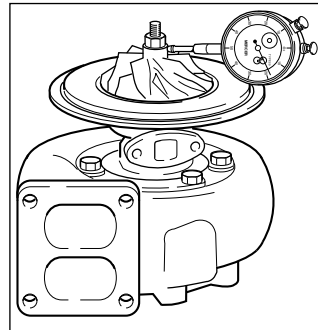
Screw, Thrust Bearing
(Item 58)Radial Movement
(TIR)

Axial Clearance

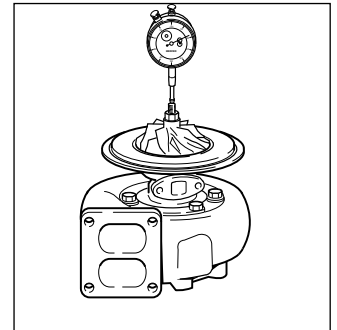

Turbo Model

Nm (lb. in)

mm (in)

mm (in)

Turbo Model	Nm (lb. in)	mm (in)	mm (in)
3 in/3A	N/A	0.254 - 0.381 (0.010 - 0.015)	0.102 - 0.178 (0.004 - 0.007)
3FD/3FE/3FJ/3LE	N/A	0.406 - 0.559 (0.016 - 0.022)	0.102 - 0.178 (0.004 - 0.007)
3LD	N/A	0.381 - 0.533 (0.015 - 0.021)	0.102 - 0.229 (0.004 - 0.009)
4 in/4B	N/A	0.305 - 0.457 (0.012 - 0.018)	0.102 - 0.178 (0.004 - 0.007)
4HD	6.8 (60)	0.381 - 0.584 (0.015 - 0.023)	0.102 - 0.178 (0.004 - 0.007)
4LE/4LF/4LG	N/A	0.356 - 0.533 (0.014 - 0.021)	0.076 - 0.178 (0.003 - 0.007)
4LEV/4LEK/4LFK	N/A	0.356 - 0.513 (0.014 - 0.020)	0.051 - 0.127 (0.002 - 0.005)
4LGK	N/A	0.381 - 0.559 (0.015 - 0.022)	0.051 - 0.152 (0.002 - 0.006)
4LGZ	N/A	0.203 - 0.635 (0.008 - 0.025)	0.051 - 0.152 (0.002 - 0.006)
4MD	6.8 (60)	0.406 - 0.584 (0.016 - 0.023)	0.102 - 0.178 (0.004 - 0.007)
4MF	N/A	0.356 - 0.483 (0.014 - 0.019)	0.076 - 0.178 (0.003 - 0.007)
6 in	N/A	0.406 - 0.584 (0.016 - 0.023)	0.102 - 0.178 (0.004 - 0.007)
6D/6LD	6.8 (60)	0.483 - 0.660 (0.019 - 0.026)	0.102 - 0.178 (0.004 - 0.007)

CAUTION

Always refer to *Service Notes* before using this service data.

Pre-H Service Data Sheet 4 of 5

Rotor Balance

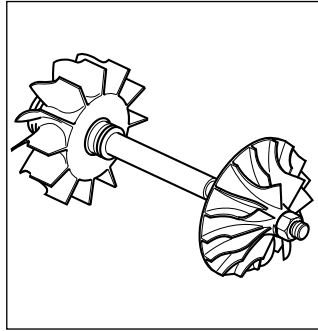

Turbo Model

g. mm (oz. in)

	g. mm (oz. in)	
	Turbine End	Compressor End
3 in/3A	1.5 (0.002)	1.5 (0.002)
3FD/3FE/3FJ/3LE	2.9 (0.004)	3.6 (0.004)
3LD	2.9 (0.004)	3.6 (0.004)
4 in/4B	2.9 (0.004)	2.9 (0.004)
4HD	2.9 (0.004)	2.9 (0.004)
4LE/4LF/4LG	4.4 (0.006)	7.2 (0.010)
4LEV/4LEK/4LFK	4.4 (0.006)	7.2 (0.010)
4LGK	4.4 (0.006)	7.2 (0.010)
4LGZ	4.4 (0.006)	7.2 (0.010)
4MD	2.9 (0.004)	2.9 (0.004)
4MF	2.9 (0.004)	2.9 (0.004)
6 in	1.5 (0.002)	1.5 (0.002)
6D/6LD	2.9 (0.004)	2.9 (0.004)

CAUTION

Always refer to [Service Notes](#) before using this service data.

Pre-H Service Data Sheet 5 of 5

Service Data Sheet Notes

- 1 The list of turbocharger models represents the majority of current specifications. If your model does not appear in the Service Data Sheets, please refer to your nearest distributor for guidance.
- 2 Service Data is sourced from Engineering Specifications and Drawings.
- 3 All permissible Service Allowances are included in this data set.
- 4 Where nominal torque is quoted always aim to achieve this mid-point value during turbocharger assembly processes.
To avoid ineffective clamp loading or plastic deformation of components through under or over tightening respectively, nominal torque must be applied using a calibrated torque wrench with not less than +/- 1 Nm (+/- 10 lbf.in) capability.
For low torque joints, use equipment that can achieve the specified calibration accuracy.
Never use breakaway torque to check clamping efficiency as this can vary up to 40% from nominal.
- 5 Some models have optional specifications (e.g. turbine housing bolts or V-band arrangements). Both are shown for reference.
- 6 European OEM's and Holset Aftermarket's torque tightening concession of 31.6 Nm (280 lb.in) now adopted in Engineering Specification.
- 7 For the latest Service Data Sheets and Bulletin Board information refer to www.holsetaftermarket.com.
- 8 Wastegate versions of H series turbochargers are pre-fixed with a "W". Refer to your nearest distributor for wastegate installation instructions.
- 9 All fasteners must be visually clean and be lubricated with light oil prior to torque tightening except where the Service Repair Manual instructs to the contrary.
Exceptions are:
 - HX20W/HX25/25W/27W Compressor Wheel Locknut, (61) V-Band Locknut, (28) - apply molycote.
 - All other V-Band Locknut (28) (29) and Wastegate Valve Body Screw (79) - fit dry.
 - All fasteners treated with a thread locking patch - fit dry and within 5 minutes of insertion.
 - Use slow tightening feed rate to prevent activation of locking patch prior to full thread engagement.

**CAUTION**

Always refer to *Service Notes* before using this service data.